

UPGRADE OF THE OPTICAL SYNCHRONIZATION SYSTEM FOR FLASH II

M. Felber*, M.K. Bock, M. Bousonville, P. Gessler, T. Lamb, S. Ruzin, H. Schlarb, B. Schmidt, S. Schulz – Deutsches Elektronen Synchrotron (DESY), Hamburg, Germany

Abstract

The optical synchronization system at the free electron laser in Hamburg (FLASH) has been in operation since 2008. Due to continuous improvement and several upgrades it has become an integral part of the machine operation and of pump-probe experiments as both rely on its performance. In summer 2013, a second FEL section, called FLASH II, which is using the same accelerator as FLASH will start its operation to increase the number of user experiments and to test new seeding schemes. This also requires a major extension of the synchronization system since new clients have to be supplied with a 10 fs-stable timing signal. Six additional stabilized fiber links and the according end stations like bunch arrival time monitors and laser synchronization setups will be installed.

THE OPTICAL SYNCHRONIZATION SYSTEM AT FLASH

For the synchronization needs of a next generation light source like FLASH and the European XFEL a pulsed optical synchronization system was proposed [1]. Compared to the alternative use of an optical cw system, the pulsed scheme has several advantages e.g. the direct use of the pulses for beam diagnostics in electron Bunch Arrival-time Monitors (BAM) [2] and the operation of balanced optical cross-correlators (OXC) [3] for the synchronization of external lasers. The pulse-train can also be used for low-noise and low-drift RF generation e.g. as reference for the LLRF [4, 5].

Consequently, such a system has been developed and operated for over three years at the FLASH facility at DESY [6].

Operation Principle

The operation relies on the starlike distribution along the accelerator of ~ 200 fs FWHM laser pulses in optical fiber with a repetition rate of 216.67 MHz. The source is a commercial laser operating at 1559 nm which output can be split to up to 16 individual fiber link stabilization units. Each unit contains passive dispersion compensation for the fiber link, a balanced optical cross-correlator [7], and two actuators for the compensation of optical length changes in the link. The first actuator for fast (few hundred Hertz) optical length changing is a fiber coiled around a piezo ceramic, called fiber stretcher. Its range is limited by software to about 7 ps in order to reduce polarization mode dispersion effects due to mechanical stress on the fiber. The second actuator situated in the

free-space optics part of the stabilization unit is a motorized delay stage which acts each time the piezo voltage of the stretcher gets to its limits. The current version of the in-house developed and built delay stage has a travel range of about 45 mm. Since it uses a retro reflector, the beam travels along the adjustment range four times providing a shifting range of about 600 ps [8].

At the end station of each fiber link, the polarization of the laser pulses is rotated by 90° and a fraction is reflected back to the stabilization unit. Here each reflected pulse is compared to a fresh reference pulse from the laser source in the optical cross-correlator. Any detected change in timing is compensated by a digital feedback controller driving the actuators.

Implementation at FLASH

The entire system is installed in small hutch close to the FLASH injector, called synchronization-hutch (Figure 1). Two lasers for redundancy, the beam splitting setup, and the link stabilization units are placed on an optical table. There is convenient space for up to 8 units, additional units have to be installed on top of the existing ones making the installation and maintenance much more complicated.

Over the past years, the system has constantly been upgraded and extended. During the daily operation several unexpected problems occurred which could be solved by redesigning the stabilization units. Additionally, the implementation of the commercial laser meant a big step towards reliability and robustness of the system.

There are seven link stabilization units in operation at the time this paper is being written (August 2011). The length of the different fiber links ranges from about 50 m to the first bunch compressor up to about 400 m to the experimental hall.

The reference signals at the end stations are used to synchronize the seed laser of the sFLASH (seeded FLASH) HHG (higher harmonic generation) experiment and the pump-probe laser [9]. The operation of four BAMs allows the users of the FEL facility to check and track the arrival time of the photon pulses which is naturally correlated to the arrival time of the electron bunches.

The biggest achievement made possible by the use of the pulsed optical synchronization system is the beam-based feedback (BBFB) which uses the information of different beam diagnostic monitors like the BAMs in order to stabilize the energy and arrival-time of the electron bunches [10, 11]. Two different types of feedbacks have been implemented. The slow feedback uses the averaged arrival-time and bunch compression of

*matthias.felber@desy.de

several macro-pulses (10 Hz repetition rate) and changes slowly the setpoint of the amplitude and phase of the RF accelerating field in order to keep these values constant. The fast feedback measures and acts within a few microseconds in order to keep the arrival-time jitter of the bunch train within one macro pulse low. Without the BBFB the jitter between the optical reference system and the electron beam in daily operation is in the order of about 50 fs rms. This value is mainly limited by the LLRF performance and the synchronization of the laser source of the system. With BBFB in operation, the intra-pulse arrival jitter is reduced to about 20 fs rms.

Nowadays, the setup of the slow feedback has become a routine procedure and is frequently asked for and made use of by the experiments.

FLASH II

The beam-time requests by potential users of the FLASH facility by far exceed the capabilities of the FEL. Therefore it was proposed by DESY and HZB to extend the existing infrastructure with a second user facility called FLASH II which uses the same accelerator like FLASH [12]. After the accelerating section the beam can be separated into both facilities. In order to also increase the beam quality, it was decided to build FLASH II as a seeded FEL making use of the HHG (high-gain harmonic generation) scheme for the entire wavelength range of 4 – 80 nm (fundamental) and HHG for wavelengths shorter than 40 nm. FLASH II will have a variable gap undulator allowing for flexible wavelength tuning independent of the FLASH operation. Additionally, the undulator is long enough for saturation from noise for SASE (self-amplified spontaneous emission) mode operation.

For the user experiments a second experimental hall

will be built next to the existing FLASH hall. A pump-probe laser is foreseen in a later stage.

OPTICAL SYNCHRONIZATION FOR FLASH II

In the course of the FLASH II extension, also the optical synchronization system has to be extended. FLASH II itself will have four additional clients of the optical reference signal which are two BAMs, the seed laser, and the pump-probe laser. The infrastructure of the synchronization system originally foreseen only for FLASH is capable of being upgraded to these needs with the drawback of the afore-mentioned space restrictions in the synchronization-hutch. During installation of the optical links along the accelerator tunnel 24 fibers were laid out to each of the 11 individual FLASH end stations while in most cases only a few are needed for operation. Therefore it is possible to make use of these installations by patching new fibers from the existing end stations in the FLASH tunnel to the new end stations in the FLASH II tunnel, without the need to lay out new fiber links from the synchronization hutch all the way down the accelerator.

PLASMA WAKEFIELD ACCELERATION AND FUTURE UPGRADES

A relatively new field in the FEL community is the electron acceleration by means of extremely strong electric fields (\sim GV/m) in plasma wakes that are driven by intense lasers, called plasma wake field acceleration (PWA) which is shown in Figure 2 [13]. Even though nowadays the energy spread of such electron beams is by far not sufficient for producing stable SASE radiation for user experiments, recent achievements show promising progress in terms of stability and other beam properties.

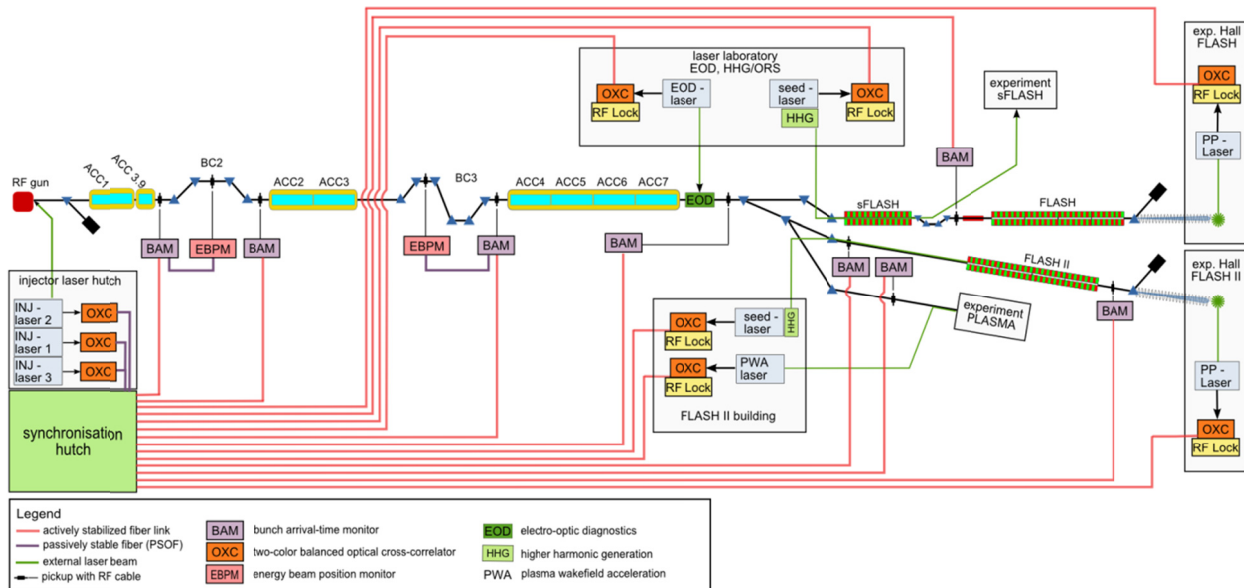

Figure 1: The optical synchronization system at its full expansion state for FLASH, FLASH II, and the plasma experiment. The local RF generation from actively phase-stabilized fiber links for the LLRF at each RF station as well as the undulator bypass beamline are left out for simplicity.

A new research group was established at DESY which will make use of the unique possibility of inserting a well-defined electron bunch into the plasma wake instead of relying on the self-build-up of the bunch by trapped electrons. For this purpose the upper floor of the new FLASH II building will be housing a laser laboratory where a 200 TW laser system will be installed. For the PWA experiment another beamline next to FLASH II situated in the same tunnel is foreseen.

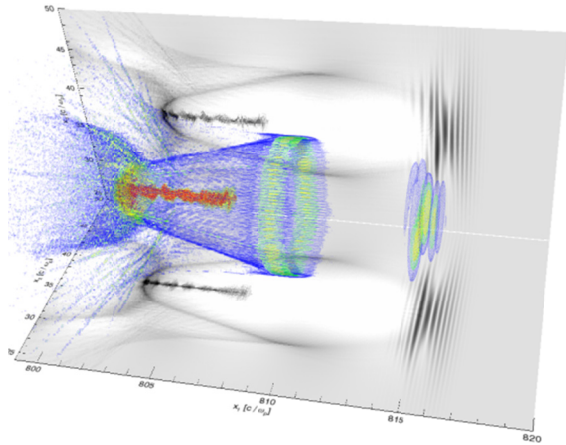

Figure 2: Simulation of plasma charge density modulation invoked by the intense laser pulse (courtesy of Timon Mehrling, DESY)

The timing jitter between laser pulse and electron bunch is extremely critical and must not exceed the plasma wavelength. The requirements for such experiments are in the order of 10 fs, therefore the PWA laser system and a dedicated BAM are additional clients of the optical synchronization system.

The current planning foresees the operation of the experiment at the facility for three years until the 2018. Afterwards the installation of a third FEL beamline, called FLASH III, is planned.

FINAL EXPANSION STATE OF THE SYSTEM

Figure 1 shows the optical synchronization system in the full expansion state planned for 2015. It is still not the whole picture since there are four additional actively stabilized fiber links planned to be installed in the near future that are based on another timing change detection principle [14]. Their end stations are newly developed RF generation setups [5] which will serve the LLRF system of the accelerator by providing an ultra-low noise and drift free reference.

Besides the two redundant injector lasers there will be a third laser installed in September 2011 which has the capability for low charge operation due to its shorter pulse

duration. The timing reference for the injector lasers is not provided via a stabilized link but by means of phase-stabilized optical fiber (PSOF) because the distance between the synchronization hutch and the injector laser hutch is sufficiently short and shielded from the environment.

Also the EBPMs [15] which are situated close to BAM end stations are supplied via PSOF patch cords.

The synchronization of external Titan:Sapphire lasers is done in two steps. First an RF-lock is established in a phase-locked loop configuration using RF signals which are generated from the reference pulse train and the laser pulse train. And in a second step the two-color balanced optical cross-correlator takes over for achieving the ultimate low-jitter synchronization.

Summary

Eventually there will be 14 link stabilization units based on optical cross-correlators and another 4 units based on another principle described in [14]. Their end stations are 8 BAMs and two EBPMs, 6 laser synchronizations, and 4 RF generation setups for LLRF. Additionally the 3 injector laser synchronizations are supplied by the optical reference via passively stable fibers.

REFERENCES

- [1] J. Kim et al, proceedings FEL 2004, TUAOS03.
- [2] M.K. Bock et al, proceedings DIPAC 2011, TUPD28.
- [3] S. Schulz et al, proceedings PAC 2009, TH6REP091.
- [4] M. Felber et al, proceedings PAC 2009, TH6REP088.
- [5] T. Lamb et al, proceedings FEL 2011, THPA32.
- [6] F. Loehl et al, proceedings EPAC 2008, TUPC135.
- [7] F. Loehl et al, proceedings DIPAC 2007, WEPB16.
- [8] M.K. Bock et al, proceedings FEL2011, WEPA19.
- [9] M. Felber et al, proceedings FEL 2010, THOA3.
- [10] W. Koprek et al, proceedings FEL 2010, THOA12.
- [11] C. Schmidt et al, proceedings FEL 2011.
- [12] B. Faatz et al, proceedings IPAC 2010, TUPE005.
- [13] J. Osterhoff et al, Phys. Rev. Lett. 101, 085002 [2008].
- [14] T. Lamb et al, proceedings DIPAC 2011.
- [15] K. Hacker, proceedings BIW 2010, MOFNB02.